

PERFECT CASH JAM CLEARANCE MANUAL

CONTENTS

1. INTRODUCTION:	2
2. DEVICE:	2
2-1.UNIT CLASSIFICATION:	2
3. JAM CLEARANCE	3
3-1. PRE-ACCEPTOR	3
3-2. UPPER MODULE	6
3-2-1. Separator picking area	6
3-2-2. Separator transport	9
3-2-3. Pre-BV transport	10
3-2-4. Bill Validation	12
3-2-5. Post-BV transport	12
3-2-6. Upper transport	14
3-2-7. Escrow transport, Escrow and Reject Reservoir	15
3-2-8. Top transport	17
3-2-9. Reject transport	19
3-2-10. Reject Bin	21
3-2-10-1. Fixed Reject Bin Type	21
3-2-10-2. Removable Reject Bin Type	23
3-3. LOWER MODULE - LOWER TRANSPORT (FRONT AND REAR COVER)	25
3-4. CASSETTES (1- 4)	28
4. COMPLETING JAM CLEARANCE PROCEDURES:	30

PERFECT CASH

a member of FireKing Security Products
Ph. 800.457.2424 • www.fireking.com

1. INTRODUCTION:

2. Device:

2-1. Unit classification:

The following shows unit combination and the sections on which the details of units are illustrated in this manual.

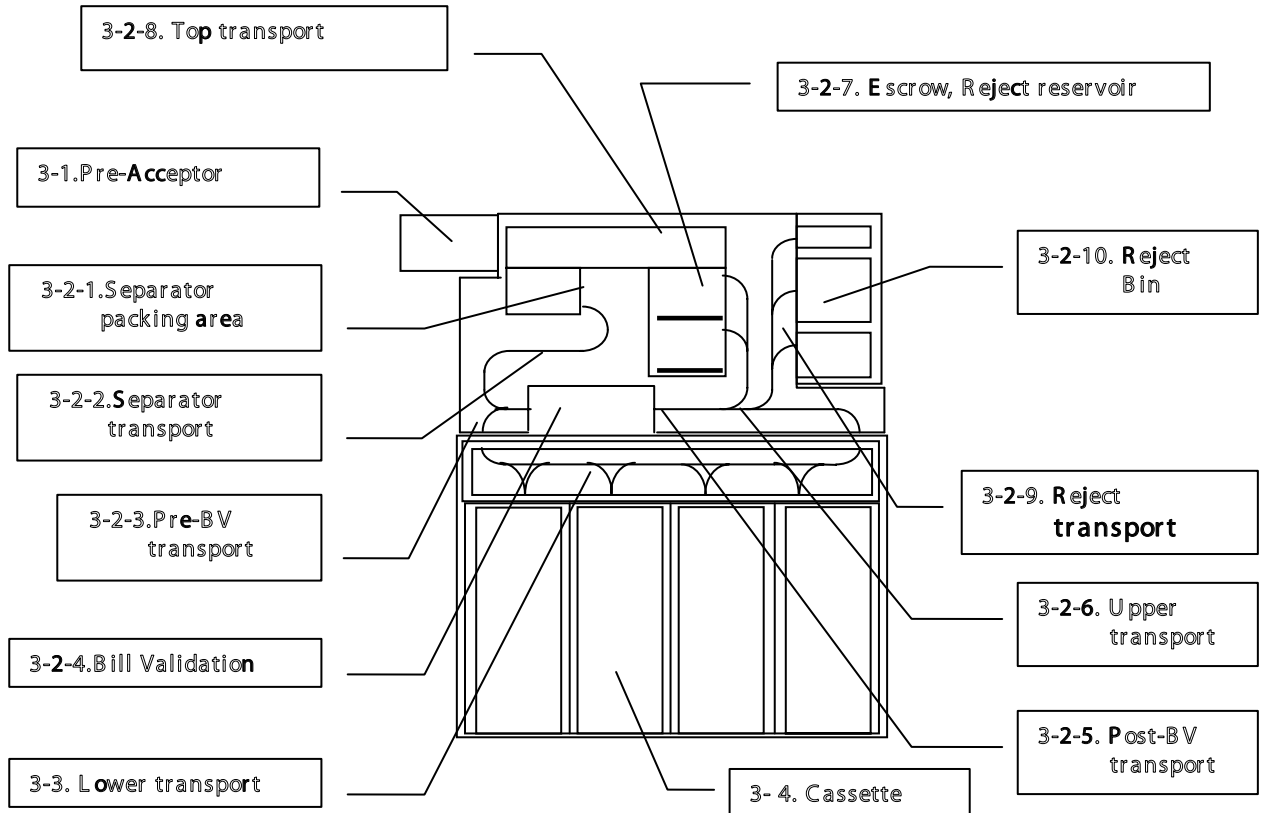

a member of FireKing Security Products
Ph. 800.457.2424 • www.fireking.com

3. Jam Clearance

3-1. Pre-acceptor

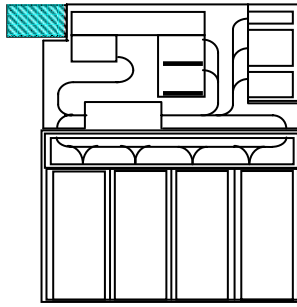

1. Raise and hold up the Pre-acceptor tab (2 places) with one hand.



2. Pull out the jammed notes from the front entry slot.



3. If the jammed notes are located near the rear of front entry slot and difficult to access, turn the green knob (No.2) counter-clockwise to move notes from front slot.

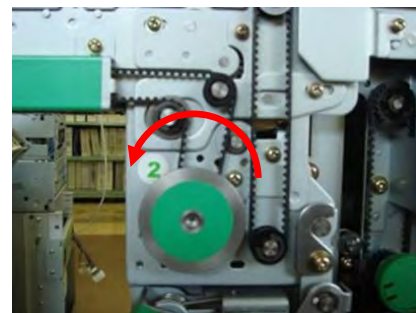

Pieces of torn notes or foreign objects must be completely removed in the following area.

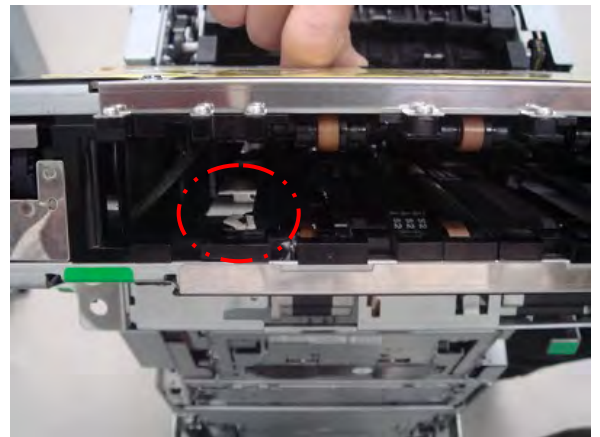
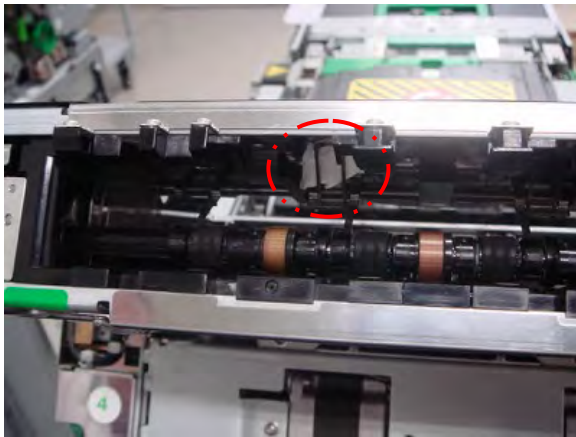
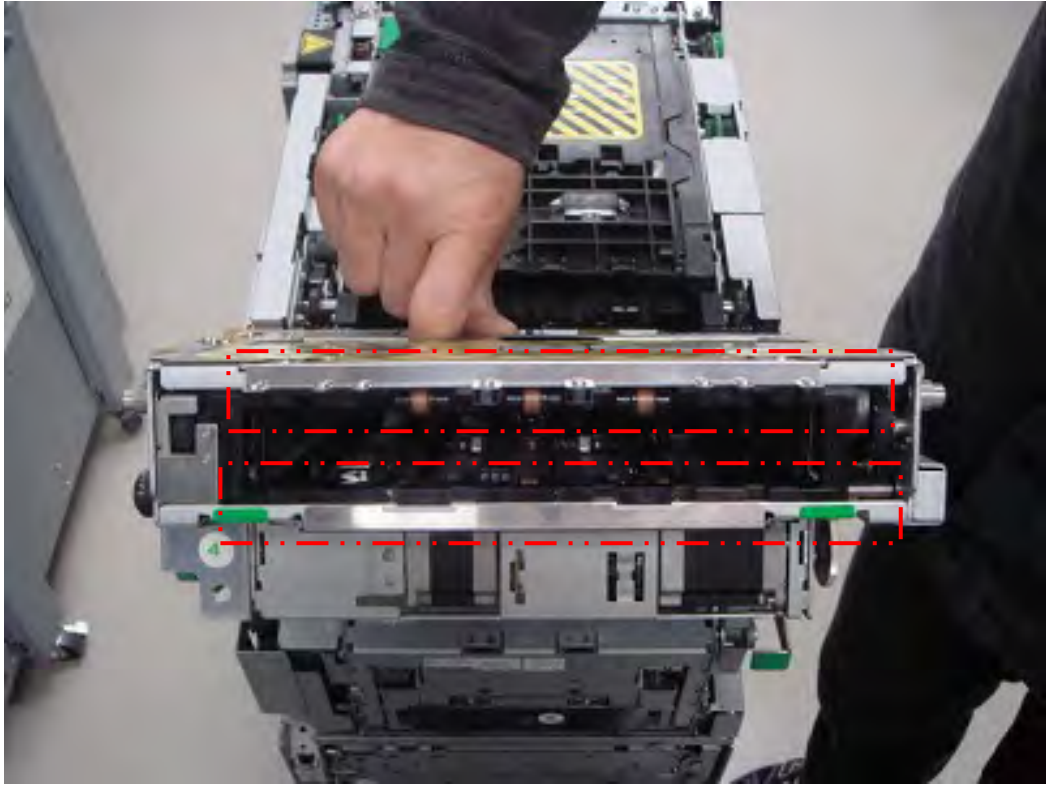

Check between bracket and upper frame, over belt and guide.
Also under the belt , roller and Mylar sheet.



a member of FireKing Security Products
Ph. 800.457.2424 • www.fireking.com

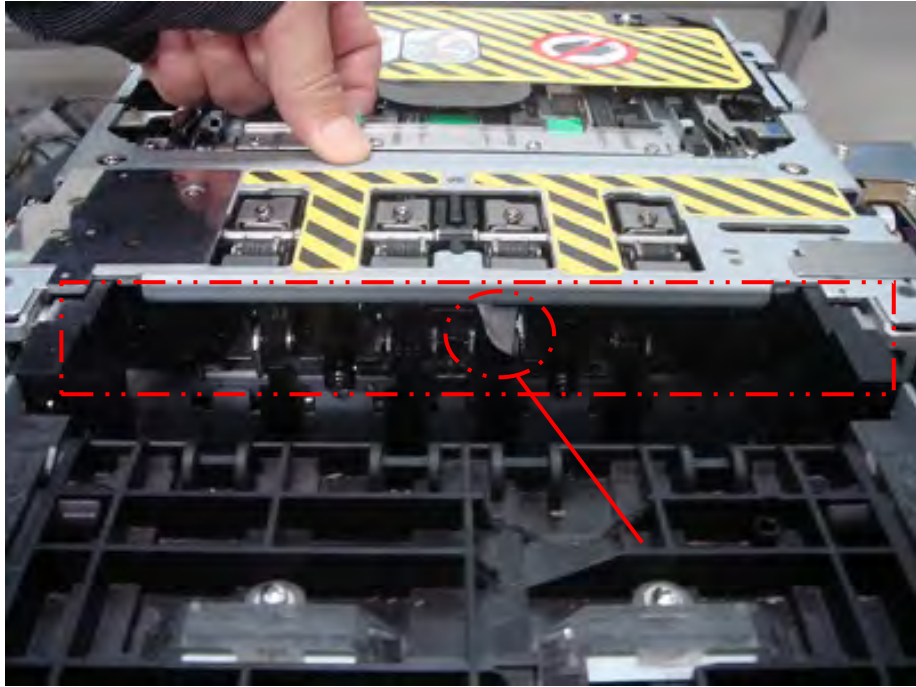

Check between frame and guide, around central lever.

PERFECT CASH

a member of FireKing Security Products
Ph. 800.457.2424 • www.fireking.com

3-2. Upper Module

3-2-1. Separator picking area

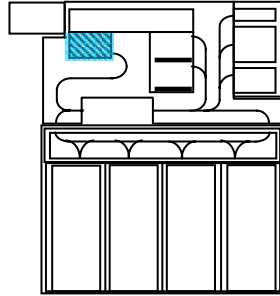

1. Hold the green handle (No.1) to turn up the pre-acceptor to make stay bar (No.5) lock into the lowest hole.

Caution: Confirm the stay bar is set firmly and safely.

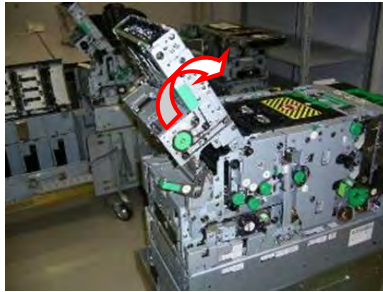

2. Pull down the panel (No.10) to access the stack area and push with one hand.

Turn stage pusher (No.8) counter-clockwise to move pusher fully up.

Turn stage knob (No.7) clockwise to move stage fully down.

If notes appear on stage and are accessible, turn knob (No.6) clockwise to move notes out.

② If notes are caught by separator and difficult to access, turn manual knob(No.18) counter-clockwise to move notes out.

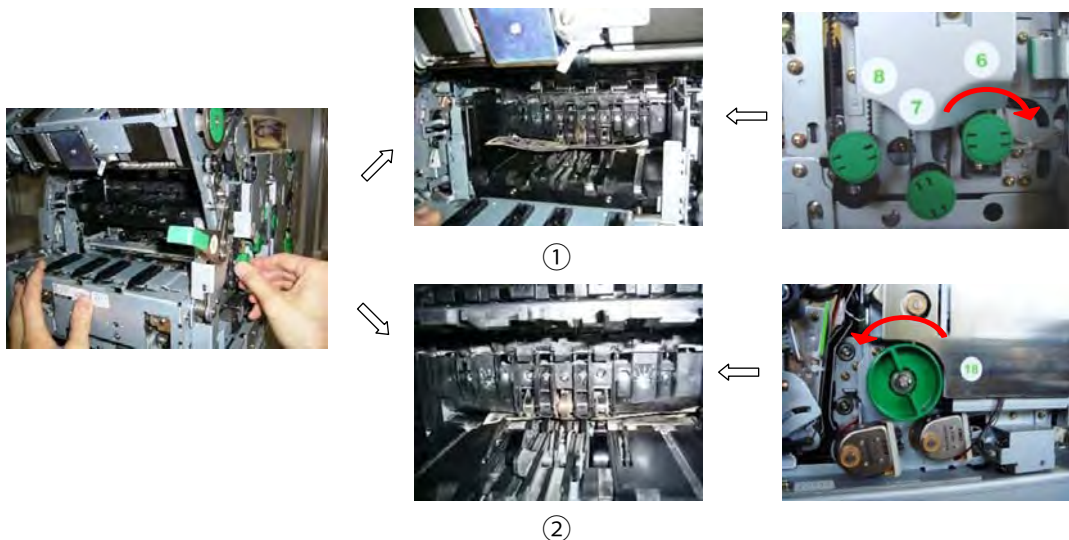

PERFECT CASH

a member of FireKing Security Products
Ph. 800.457.2424 • www.fireking.com

Caution: Don't draw the notes if notes are caught by separator. Turn the knob until notes are released.

3. To close the pre-acceptor, lift up slightly by holding green handle (No.1). Turn the level (No.5) to release the stay bar and slowly put down the pre-acceptor.

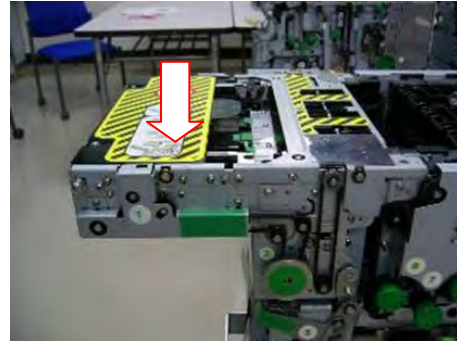

Open top module:

Hold the green handle to pull up the upper module until the gas strut is fully extended. make sure the upper module has locked firmly.

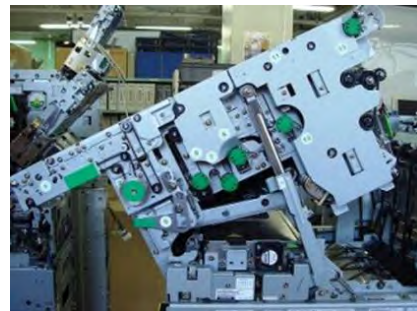

Caution: Notes can be located in any area listed above, it is recommended that all notes are removed from the above area before closing top transport.



a member of FireKing Security Products
Ph. 800.457.2424 • www.fireking.com

Pieces of torn notes or foreign objects must be completely removed in the following area.

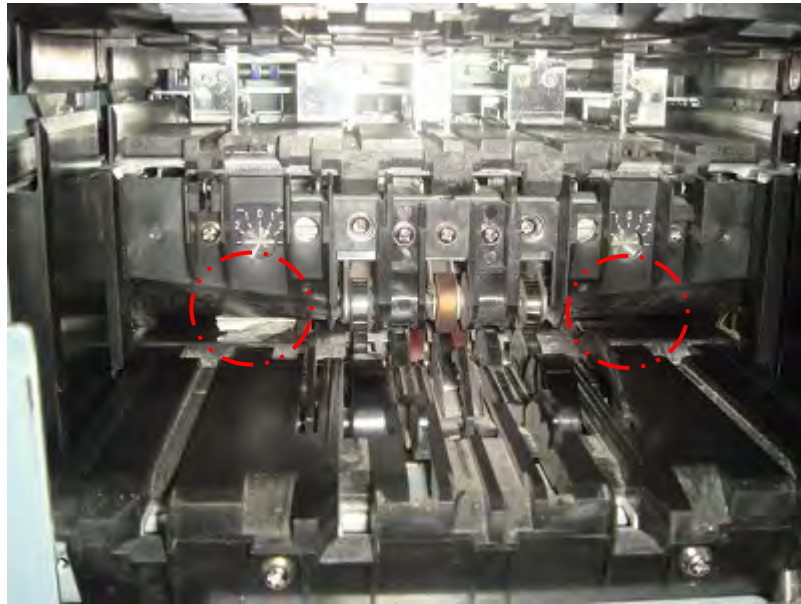

Check transportation entrance area.

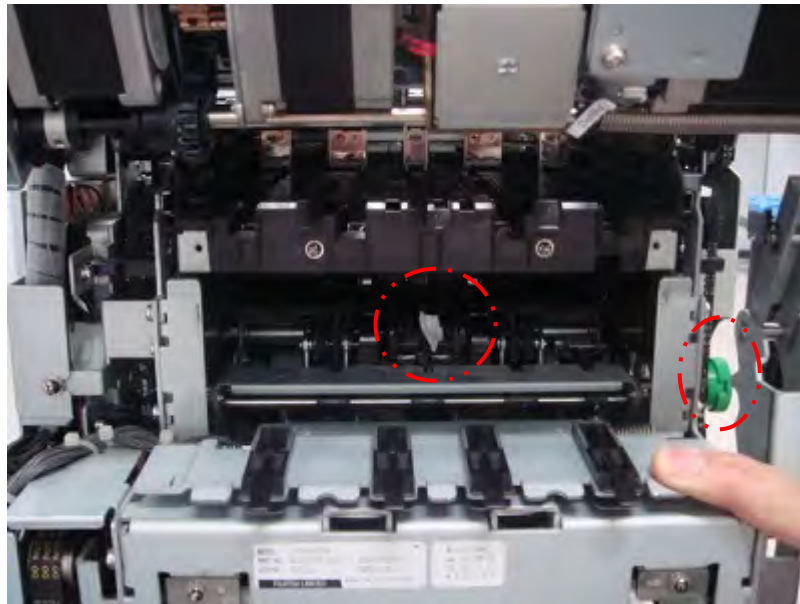

Under the Stage and lever area :
Turn the manual knob in clockwise.

PERFECT CASH

a member of FireKing Security Products
Ph. 800.457.2424 • www.fireking.com

3-2-2. Separator transport

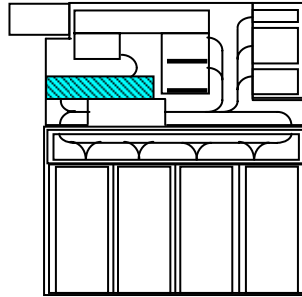

Open the top module to view and access the bottom part of separator.



If notes are not immediately accessible, turn green knob (No.18) counter-clockwise to move notes out. When notes are accessible, remove notes carefully from the module.

Pieces of torn notes or foreign objects must be completely removed in the following area.

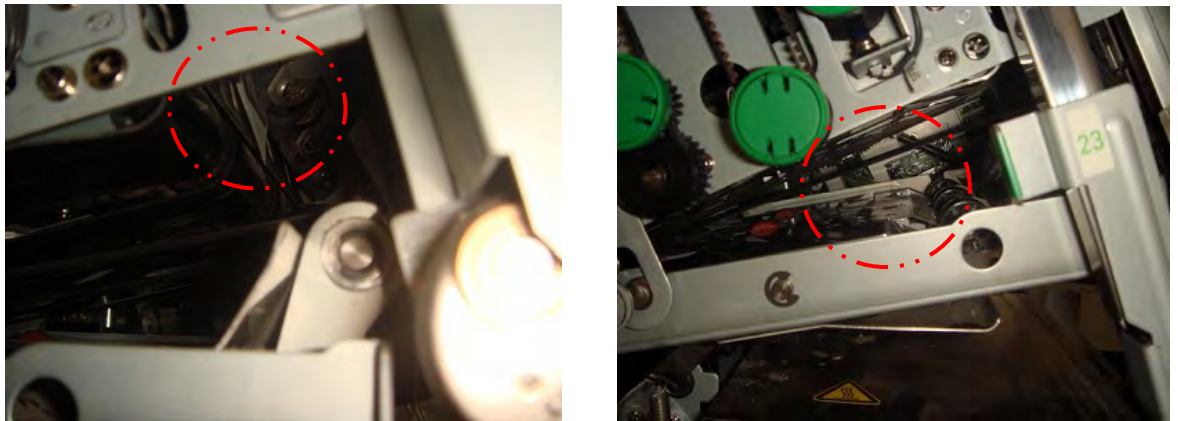

Check these transportation guide and belt areas.

Note : Use a flashlight.



a member of FireKing Security Products
Ph. 800.457.2424 • www.fireking.com

3-2-3. Pre-BV transport

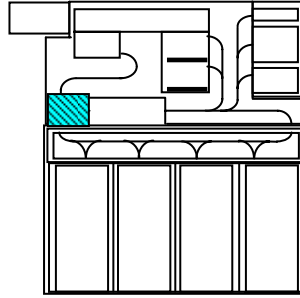

The top module must be opened as to access Post-transport.
To clear any jammed notes at pre-BV transport, first remove any notes from BV and post-BV transport.

1. Hold the plastic sheet (No.9) with one hand and remove the screw (2 places) from cover at the front of separator. Take care not to crush the plastic sheet.



2. Grip the 2 green levels to pull out the front cover.



PERFECT CASH

a member of FireKing Security Products
Ph. 800.457.2424 • www.fireking.com

3. If notes are caught by shafts and cannot be removed immediately, turn the knob (No.18) clockwise and counter-clockwise some times to make notes slack form the shafts. Carefully remove notes from the front side.

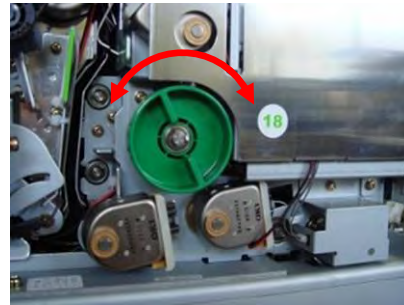

4. If notes is too tight to be removed from the front side. With top module closed, turn knob (No.18) clockwise to reverse transport. This action can return notes from pre-BV back into the separator, where the notes can be removed.

5. Remove notes from BV entry.



Pieces of torn notes or foreign objects must be completely removed in the following area.

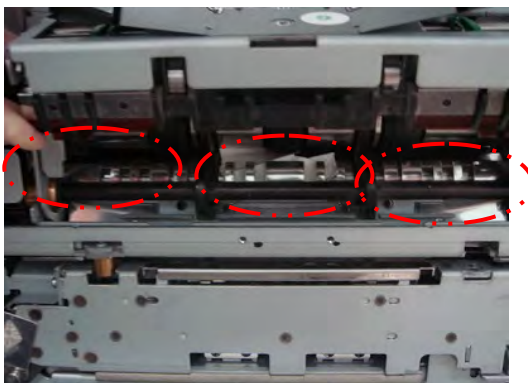

Check between transportation guide area.

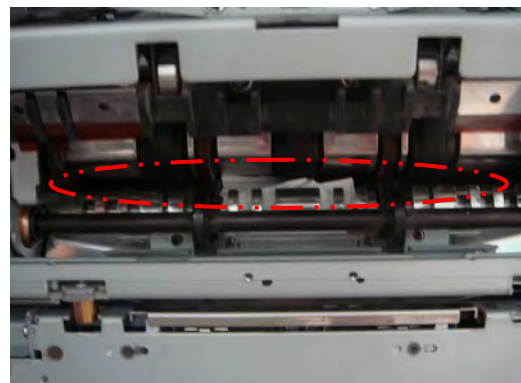

Transportation entrance area as well.



a member of FireKing Security Products
Ph. 800.457.2424 • www.fireking.com

3-2-4. Bill Validation

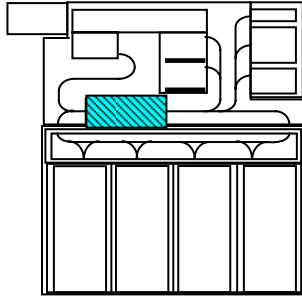

The top module must be opened as to access BV

1. Hold the BV lid (No.17) to open BV unit.



2. If notes are pinched between the BV shafts, Turn knob (No.18) clockwise to move notes out, carefully remove notes from inside the BV. Take care not to draw notes strongly.

3. Close BV cover and make latch clicks into home position.

3-2-5. Post-BV transport

The top module must be opened as to access Post-transport.

If notes are difficult to access, turn knob (No. 18) to move notes out. Remove notes from the transport. Take care not to draw notes strongly to damage notes.

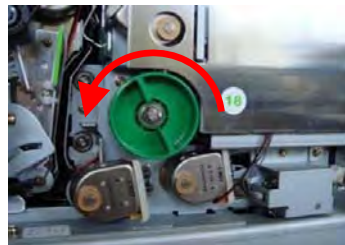

PERFECT CASH

a member of FireKing Security Products
Ph. 800.457.2424 • www.fireking.com

Pieces of torn notes or foreign objects must be completely removed in the following area.



Check transportation shaft/side area and around the guide.



Around the guide entrance as well.

PERFECT CASH

a member of FireKing Security Products
Ph. 800.457.2424 • www.fireking.com

3-2-6. Upper transport

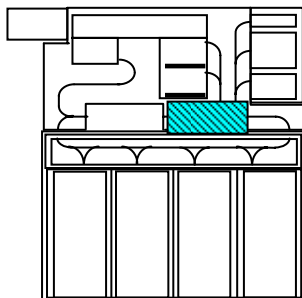

To access any notes on upper transport, open the top module at first.
Remove the jammed notes from the upper transport.



PERFECT CASH

a member of FireKing Security Products
Ph. 800.457.2424 • www.fireking.com

3-2-7. Escrow transport, Escrow and Reject Reservoir

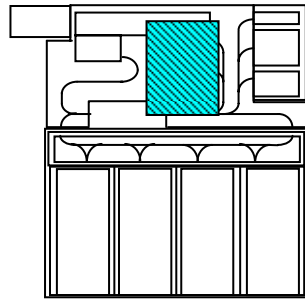

The top module must be opened in order to access the Escrow transport, Escrow and Reject Reservoir.

1. If the notes are caught by the gates, turn green knob (No.18) clockwise to move notes from the gates.

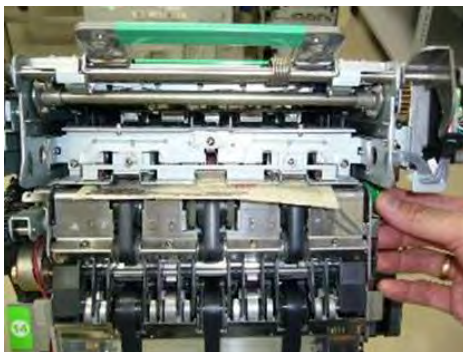

2. Pull back the green tab (No.14) to open escrow transport. The escrow and reject reservoir are behind the transport.



PERFECT CASH

a member of FireKing Security Products
Ph. 800.457.2424 • www.fireking.com

3. Turn knob (No.16) to move the notes clamped on the gates to accessible transport.
Don't draw the notes through gates to remove notes.

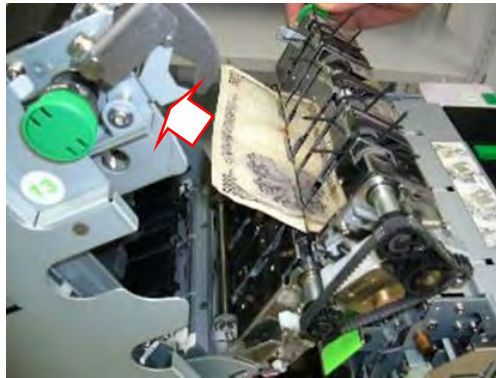

4. Turn the green knob (No.12) to move reservoir stage up or down.
Turn the green knob (No.13) to move escrow stage up or down.

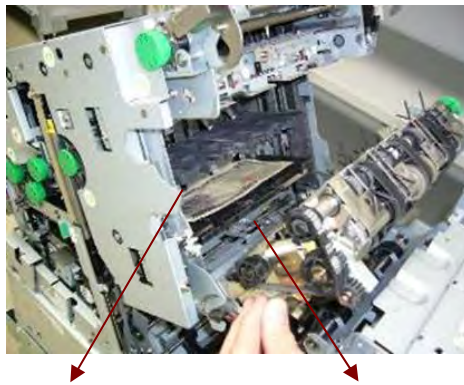

Reservoir stage

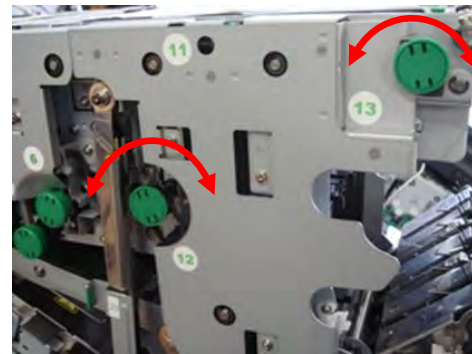

Escrow stage



5. When notes are cleared, close escrow transport. Ensure the latch clicks into the home position.

Closing the top module

6. Hold the handle (No.20) and pull up the upper module slightly and then push forward the green tab (No.23) to release the gas strut.

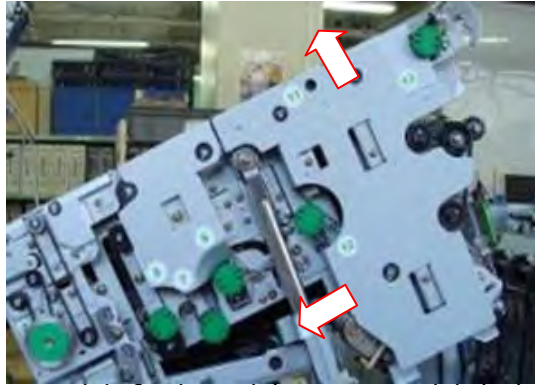

7. Push down the upper module firmly until the upper module locks into the home position.
Note: Check the lock condition after closing the top module. Improper lock will cause operation error.

Warning: Take care not to pinch the fingers when closing top module.

3-2-8. Top transport

To clear the jams on the top transport, proceed as follows:

1. Grasp the latch (No.15) to pull up the transport cover to appropriately 45°, there can view the note carrier and escrow stage.

If the carrier is located over the stage and notes are not accessible. Turn the green knob below to move the carrier.

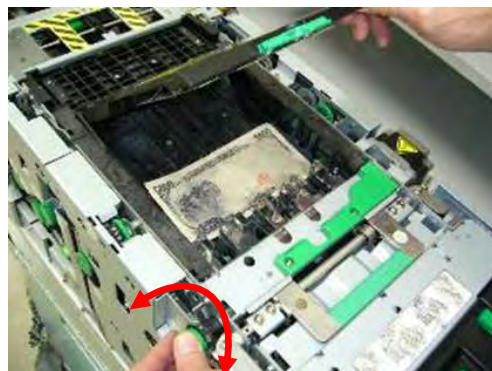

PERFECT CASH

a member of FireKing Security Products
Ph. 800.457.2424 • www.fireking.com

2. When the notes are accessible, carefully remove the notes from the transport area.



3. Close the cover, ensure the latch (No.15) clicks into home position.



Pieces of torn notes or foreign objects must be completely removed in the following area.

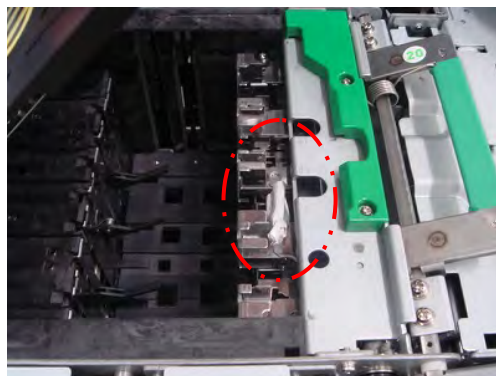

Check under the upper-flame area



a member of FireKing Security Products

Ph. 800.457.2424 • www.fireking.com

3-2-9. Reject transport

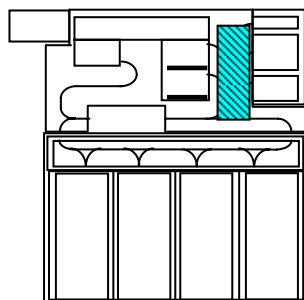

1. Pull up the green tab (No.21) to open the reject transport.



2. If the notes are sandwiched between the gates, Turn green knob (No.18) clockwise to release notes from gates and move the notes to an accessible position.

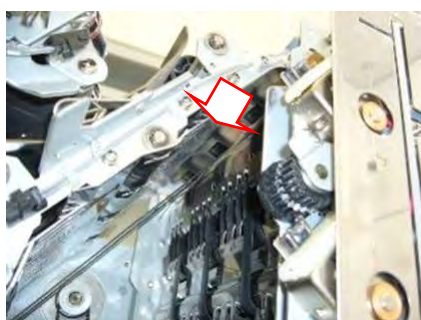
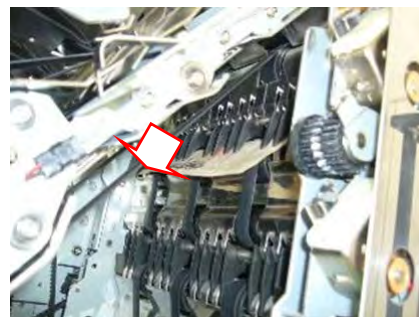
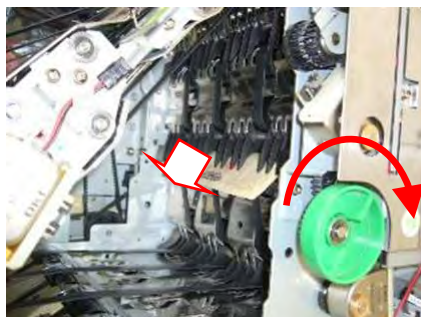

a member of FireKing Security Products
Ph. 800.457.2424 • www.fireking.com

3. Release reject transport prior to closing the top transport, it is not locked but should return back into the home position.

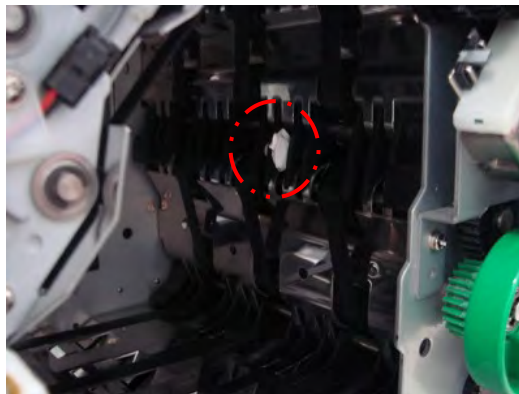
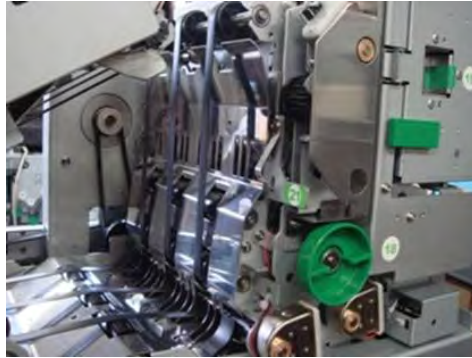

Check the transportation belt, guide, gate area

PERFECT CASH

a member of FireKing Security Products
Ph. 800.457.2424 • www.fireking.com

3-2-10. Reject Bin

3-2-10-1. Fixed Reject Bin Type

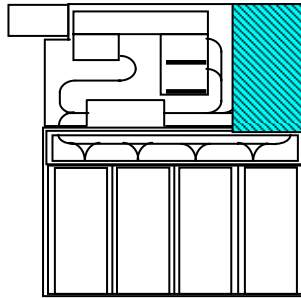

To clear jams located in the cassette transport and fixed reject bin, proceed as follows.

1. Remove the reject bin door seal (if fitted)
2. Pull out the door handle to open the reject bin door.

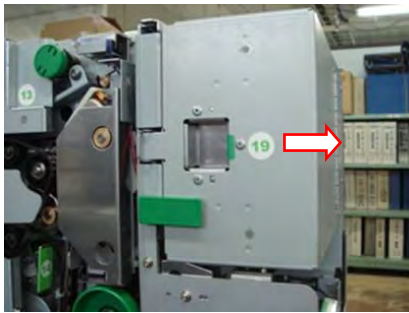

Counterfeit

Reject

3. If the notes are caught by gates, turn green knob (No.18) to move notes to accessible position. Carefully remove the notes from reject bin.

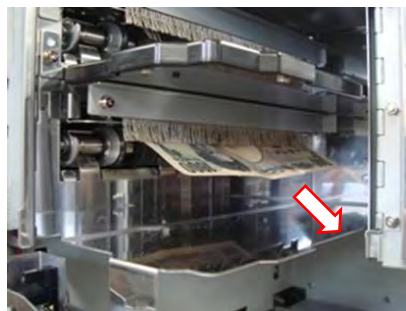

a member of FireKing Security Products

Ph. 800.457.2424 • www.fireking.com

4. The cassette transport is located under the fixed reject bin. Pull up the latch (No.22) to open the cover.

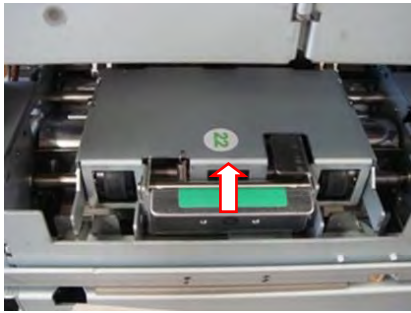

5. If the notes are not immediately accessible, turn green knob (No.18) to move notes through the transport. Carefully remove any notes from the transport.



6. To close the cover, push down the latch (No.22) ensuring it returns back to home position.

Note: If the cover is not latched properly, an error message will be displayed.

PERFECT CASH

a member of FireKing Security Products

Ph. 800.457.2424 • www.fireking.com

3-2-10-2. Removable Reject Bin Type

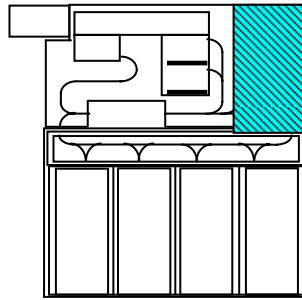

To clear the jammed notes in the cassette transport and reject bin, proceed as follows:

1. Press the green button (No.19) to release the bin.



2. Use the green handle to pull up the reject bin.
3. Check the entry slot on the back of reject bin and remove the jammed notes carefully.



PERFECT CASH

a member of FireKing Security Products

Ph. 800.457.2424 • www.fireking.com

4. Pull up the bin latch to open the reject bin. Remove any jammed notes inside the bin.

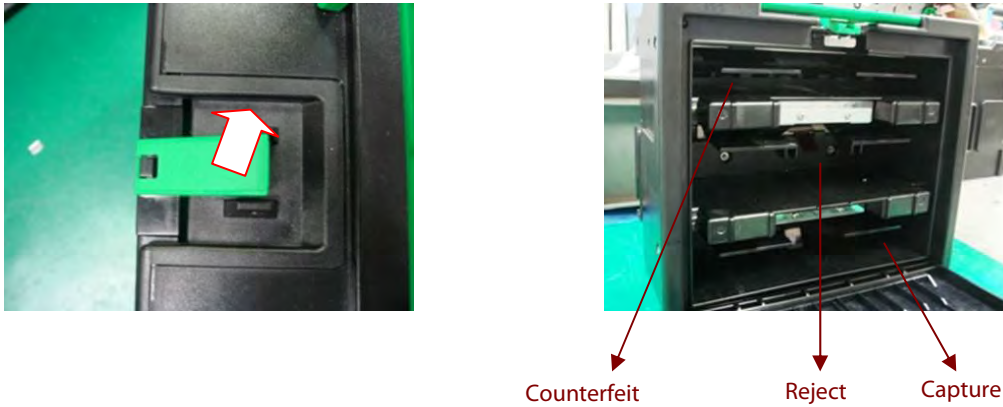

5. Close the reject bin and latch the cover.

6. Clear the jammed notes in the transport, if notes are not immediately accessible, turn green knob (No.18) to move the notes from transport.



7. To clear the jammed notes in cassette transport, refer to Clause 3-3-9-1.Item 5-7.

Caution: Make sure the cassette transport is properly closed before restoring the reject bin to prevent damaging the unit.



3-3. Lower Module- Lower transport (front and rear cover)

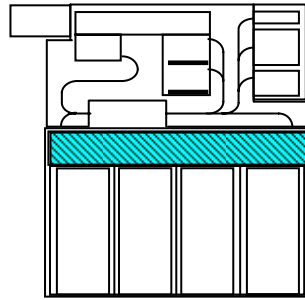

Accessing the lower module

To access the lower module, proceed as follows.

1. Push the latch (No.28) and pull it out using green handle (No.29)

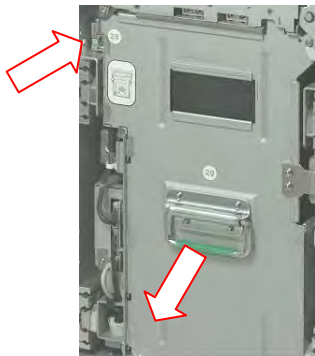

2. Proceed to the jam clearance procedure as follows.

To clear the jammed notes in lower transport, proceed as follows.

1. Push the two green latches in the two slots (No.26, 27) to open the covers.



PERFECT CASH

a member of FireKing Security Products

Ph. 800.457.2424 • www.fireking.com

2. Remove any notes on transport.



3. If notes are jammed in the gates. Pull up the green handle (No.25) on the lower transport and use it to lift up the transport and use it to lift up the transport.



Notes jammed in the gates

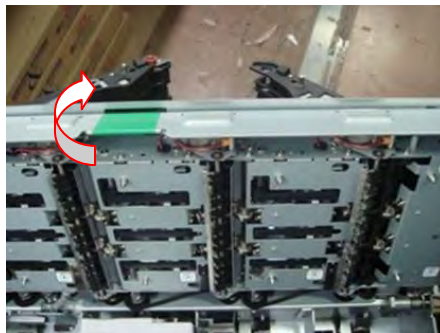

4. Turn the green knob (No.24) to move notes from gates.



PERFECT CASH

a member of FireKing Security Products

Ph. 800.457.2424 • www.fireking.com

5. Remove the notes from transport carefully.

Note: If notes are jammed in gates, don't draw the notes by force, otherwise the notes should be damaged.

6. Close the lower transport ensuring it is properly latched in home position.

Pieces of torn notes or foreign objects must be completely removed in the following area.

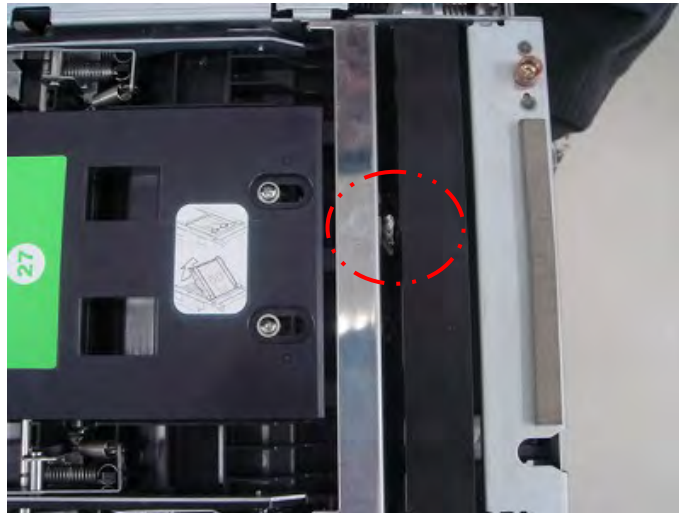

Check between the guide.

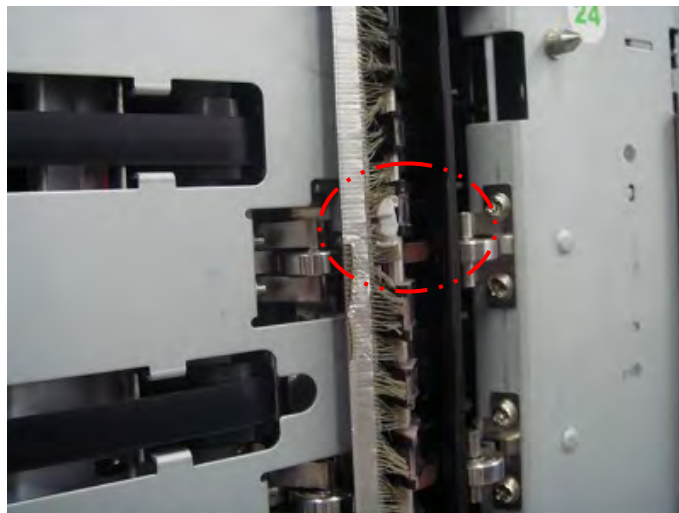

Check between brush and guide.



a member of FireKing Security Products
Ph. 800.457.2424 • www.fireking.com

3-4. Cassettes (1- 4)

Note: Deposit cassette or recycle cassette may be configured. The jam clearance procedures are the same for two types.

1. Pull up the lower transport using the green handle on transport.

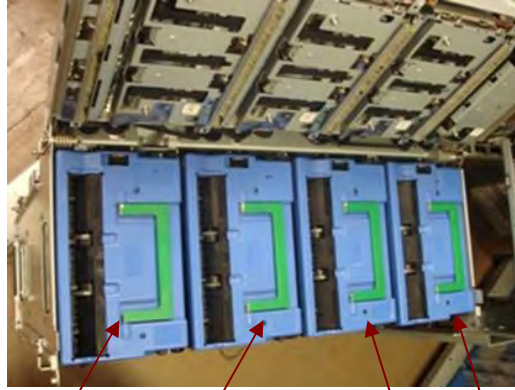

2. Lift up the cassette and out of the lower module using green handle.

3. If notes are jammed in the entry of cassette, turn the gear as below to move notes into cassette.

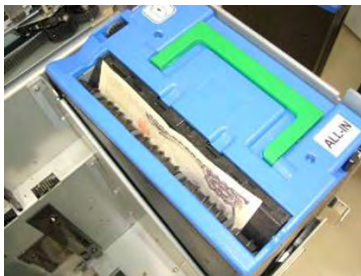

Deposit cassette



Recycle cassette



4. Release the cassette latch and open the cassette.



5. Pull down the stage and hold to release the pressure.



Deposit cassette



Recycle cassette

Note: Take care not to release the stage quickly and prevent fingers pinching between the stage and cassette.

6. Clear the jammed notes on the transport.



Deposit cassette



Recycle cassette

Pieces of torn notes or foreign objects must be completely removed in the following area.



Check between guide and roller areas.



a member of FireKing Security Products

Ph. 800.457.2424 • www.fireking.com

4. Completing Jam Clearance Procedures:

1. Make sure that all sub-modules, cassettes and transports are returned to their home positions.
2. Push lower module back into the device and lower module latch (No. 28) clicks into home position
3. Use the testing program to ensure the devices is operating properly and clearing any error messages.
4. Close and lock the security enclosure.
5. Return the machine to normal mode and then lock the machine.

PERFECT CASH

a member of FireKing Security Products

Ph. 800.457.2424 • www.fireking.com